



## BASIC BUILDING INSTALLATION GUIDE

[www.BetterBuiltBuildings.com](http://www.BetterBuiltBuildings.com)

## BASIC BUILDING INSTALLATION GUIDE

### THINGS EVERY BUYER SHOULD KNOW

Congratulations on purchasing the finest metal building available on the market today! You can anticipate many years of virtually maintenance free and reliable service from your structure.

Before you begin installation of your building there are several important points that must be considered!

While these buildings are certainly capable of being installed by the end user, we recommend that you use a properly qualified installation service. Regardless of whom you choose to install your building we urge that the provided INSTALLATION GUIDE is carefully read and that our recommendations are adhered to.

**NOTE:** Customer is responsible for all permits and easements required for their area. Engineering is available by a California State Licensed Engineer (fee required).

### T A B L E O F C O N T E N T S

SAFETY & HAZARD INSTRUCTIONS	PAGE 1
BUILDING PACKAGE	PAGE 2
PREPARATION FOR INSTALLATION	PAGE 3
ATTACHING THE BASEPLATES	PAGE 5
ASSEMBLING TRUSSES AND LEGS	PAGE 6
STANDING TRUSS/LEG ASSEMBLY	PAGE 7
HORIZONTAL ROOF SHEETING	PAGE 8-9
VERTICAL ROOF SHEETING	PAGE 10-14
INSTALLING SIDE WALL SHEETING	PAGE 15
INSTALLING TRIM	PAGE 16
SCREW SCHEDULES (SHEETING)	PAGE 17
SCREW SCHEDULES (FRAMING)	PAGE 18
FRAMING DOORS & WINDOWS	PAGE 19
ASSEMBLY OF COLLAR-TIE BRACING	PAGE 20

# theCOREsystem™

## SAFETY & HAZARD INSTRUCTIONS

**Read the following safety warnings and all instructions in their entirety prior to installation.**

### WARNING

Metal parts may get hot when exposed to high heat or direct sunlight. Avoid contact with skin and wear protective gloves and clothing to prevent the possibility of burns.

### WARNING

Do not stand or walk on the structure. It is not designed or intended to support human weight or the storage of materials on the roof. Collapse of the structure may cause serious injury due to the weight of the components.

### WARNING

Avoid installation on windy days as wind may create hazards during the installation process. Wind may blow material or cause partially installed components to collapse prior to being secured or fully installed. The weight of the components or structure may cause serious injury if it should collapse.

### WARNING

Metal conducts electricity and electrical shock hazards exist since the structure is made of metal. During installation or storage, keep the structure and all components away from electrical sources. Make sure that your selected location is away from power lines, underground cables, and any other source of electrical power. Serious injury or even death may occur if contact is made with electrical current.

### WARNING

If the structure is moved once it has been installed, be certain to inspect all components and connections and follow each and every step of these instructions to make certain that the structure is securely anchored, properly installed, and aligned accordingly. Failure to follow these steps could lead to collapse of the structure and may result in serious risk of injury.

### WARNING

In the event that your structure is enclosed, be sure to provide proper and adequate ventilation and egress and ingress. Hazardous, poisonous or noxious substances should not be stored in the structure without proper ventilation and following all warnings and instructions of the manufacturer of the substances. Also, proper ingress and egress should be provided to prevent persons or children from becoming trapped inside the structure.

### WARNING

Be careful when handling the metal panels that form the "skin" of your structure. They have sharp edges which may cause cuts or lacerations. Wear protective gloves and suitable clothing for protection and always take care when handling metal parts.

# theCOREsystem™

## THE BUILDING PACKAGE

The actual number of each individual component will vary depending on the size of your structure. However, each package will contain all of these different types of components.

**NOTE:** Your package **will not** contain any anchoring system parts such as "red heads" or core anchors™, or other extras such as vapor barrier sheets.

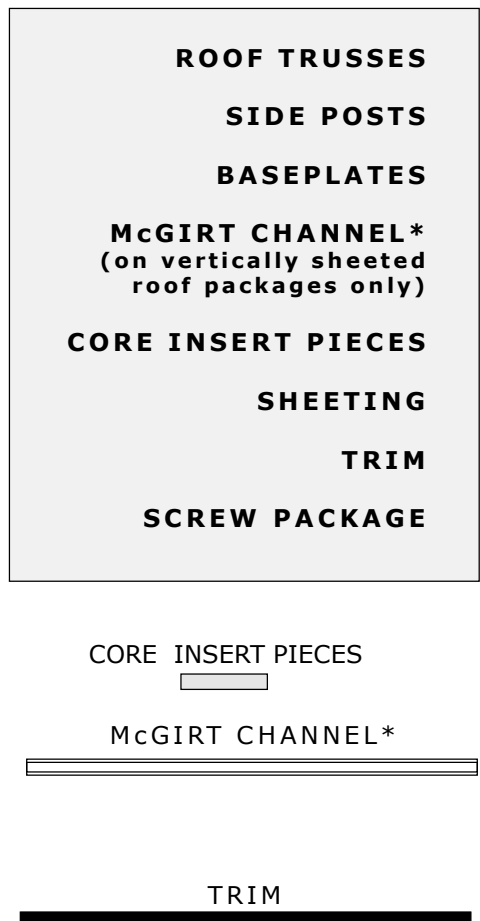
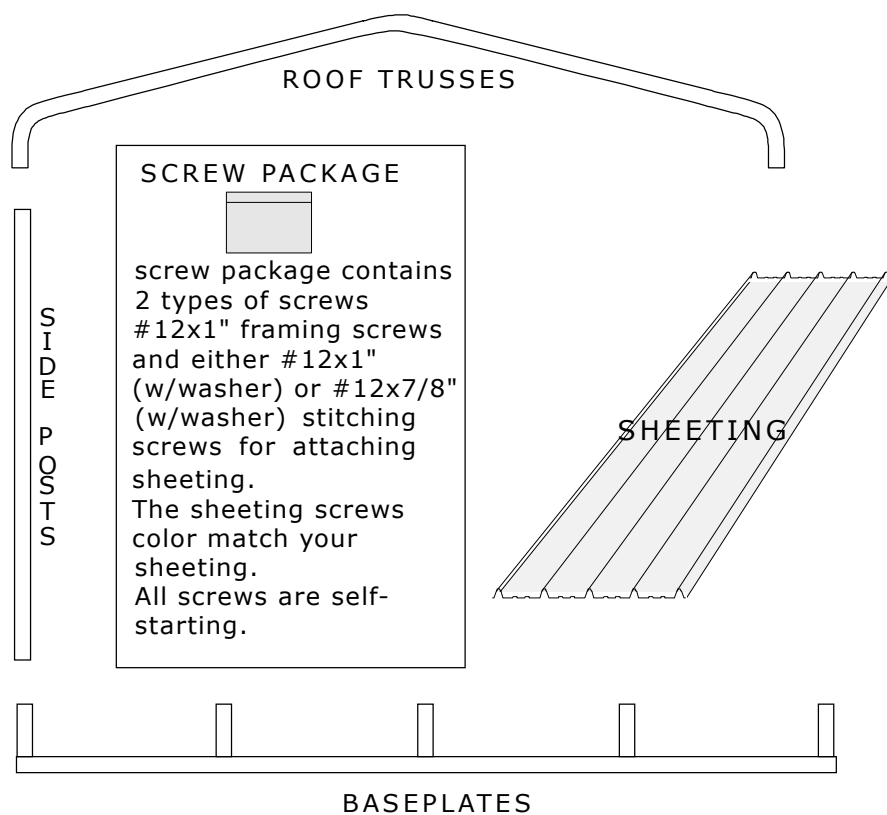

## BASIC TOOLS YOU WILL NEED

- |   |              |
|---|--------------|
| Step ladders (2 minimum) or scaffolding           | Tape measure |
| Hammer, sledge hammer                             | Shovel       |
| Electrical drill with 5/16" socket drive          | Level        |
| Gloves and protective clothing and safety glasses | Tin snips    |

# theCOREsystem™

## PREPARATION FOR INSTALLATION

As you know your building can be installed on a variety of surfaces such as dirt, asphalt, concrete slab, stem walls, continuous footings, piers, etc. However, regardless of which surface applies to your job, we cannot emphasize enough the need to prepare such surface properly.

**There is no substitute for a careful and proper preparation of your site.**

### The Site Itself

REGARDLESS OF THE ACTUAL SURFACE UPON WHICH YOUR BUILDING WILL STAND, THE **SURFACE MUST BE LEVEL**. THAT IS, IF YOU ARE INSTALLING ON A CEMENT PAD, THIS PAD MUST BE LEVEL (FRONT TO BACK, AND SIDE TO SIDE). IF YOU ARE INSTALLING ON A SURFACE THAT REQUIRES FOOTINGS OR PIERS, THESE FOOTINGS OR PIERS MUST ENABLE THE BUILDING TO STAND LEVEL, THE SAME AS ON A PAD.

**NOTE:** IF INSTALLING ON A PAD, THE ENGINEERING DRAWINGS WILL SHOW IN DETAIL HOW WE RECOMMEND THE PAD AND SPECIFICALLY THE PAD PERIMETER TO BE POURED.

ALWAYS FOLLOW PROPER LOCAL CODE REQUIREMENTS AS TO METHOD OF ATTACHMENT-DEPTH OF FOOTINGS, ETC.

### Preparing For Baseplate Attachment

#### ON FOOTINGS

Number of footings required varies depending on the length of the building (buildings take 5 per side for every 20' of length). The depth of the footings can vary from 24" deep to 30" deep depending on the wind/snow load requirement for area where structure is installed.

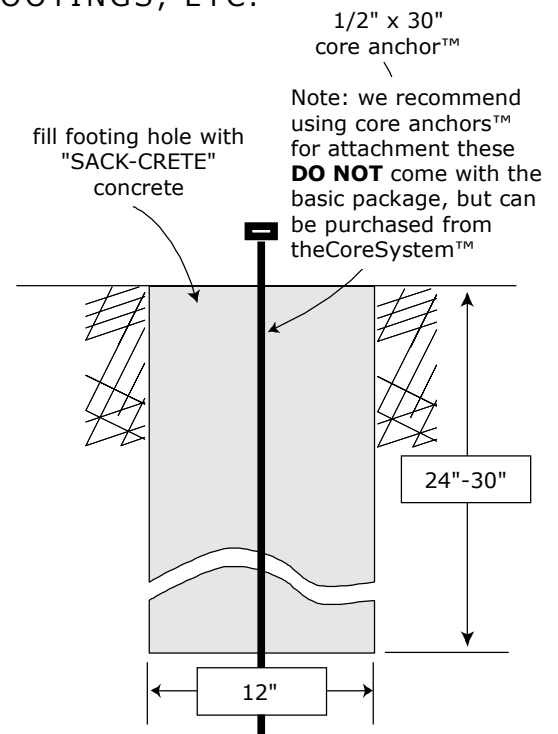

# theCOREsystem™

## PREPARATION FOR INSTALLATION

### Preparing For Baseplate Attachment

#### ON CONCRETE SLAB

Anchor bolts can be epoxied into the slab surface and then the baseplates attached to them or, you can use a rotary hammer and "redheads" to attach baseplate to slab. Number of anchor bolts or "redheads" required varies depending on the length of the building (buildings take 5 per side for every 20' of length).

core anchor™ (or anchor bolts) or "red heads" to attach baseplate to slab (installed after baseplate set)

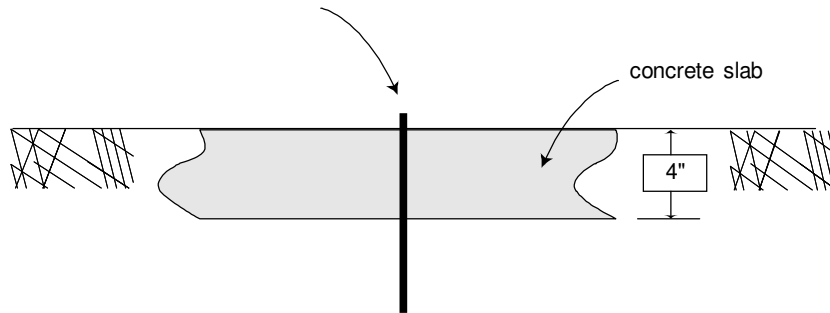

#### SEMI-PERMANENT (DIRECTLY INTO EARTH OR ASPHALT)

First consult local code requirements. Then if permissible use ground anchors. Number of ground anchors required varies depending on the length of the building (buildings take 5 per side for every 20' of length). Holes are drilled into baseplate and ground anchor passed through.

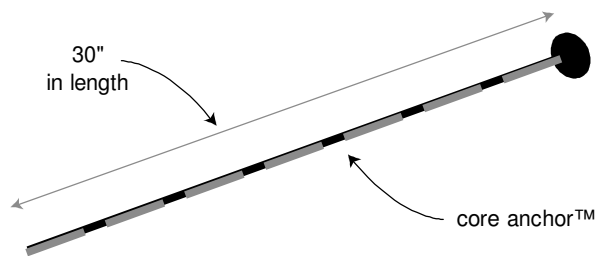

**NOTE:** Supplies (such as "redheads", core anchors™ (ground anchors), or bolts) needed to attach baseplate to your surface are **NOT** included in the basic package.

# theCOREsystem™

## ATTACHING THE BASEPLATES

The "left"(A1) and "right"(A2) baseplates come fully assembled. Position the baseplates on level ground, footings, or your concrete pad/slab. Be sure that you have them exactly equidistant or parallel. Check this by measuring diagonally. These **measurements must be equal**. Any mistakes here will cause major problems as the assembly process progresses. Also check the side to side measurements (from the outside edges of the baseplates (see diagram). This will ensure that the final results are square. Now anchor one of the baseplates to your surface. Repeat your measurements again, making adjustments as needed to the unanchored baseplate. **When all measurements are exact**, anchor the second baseplate.

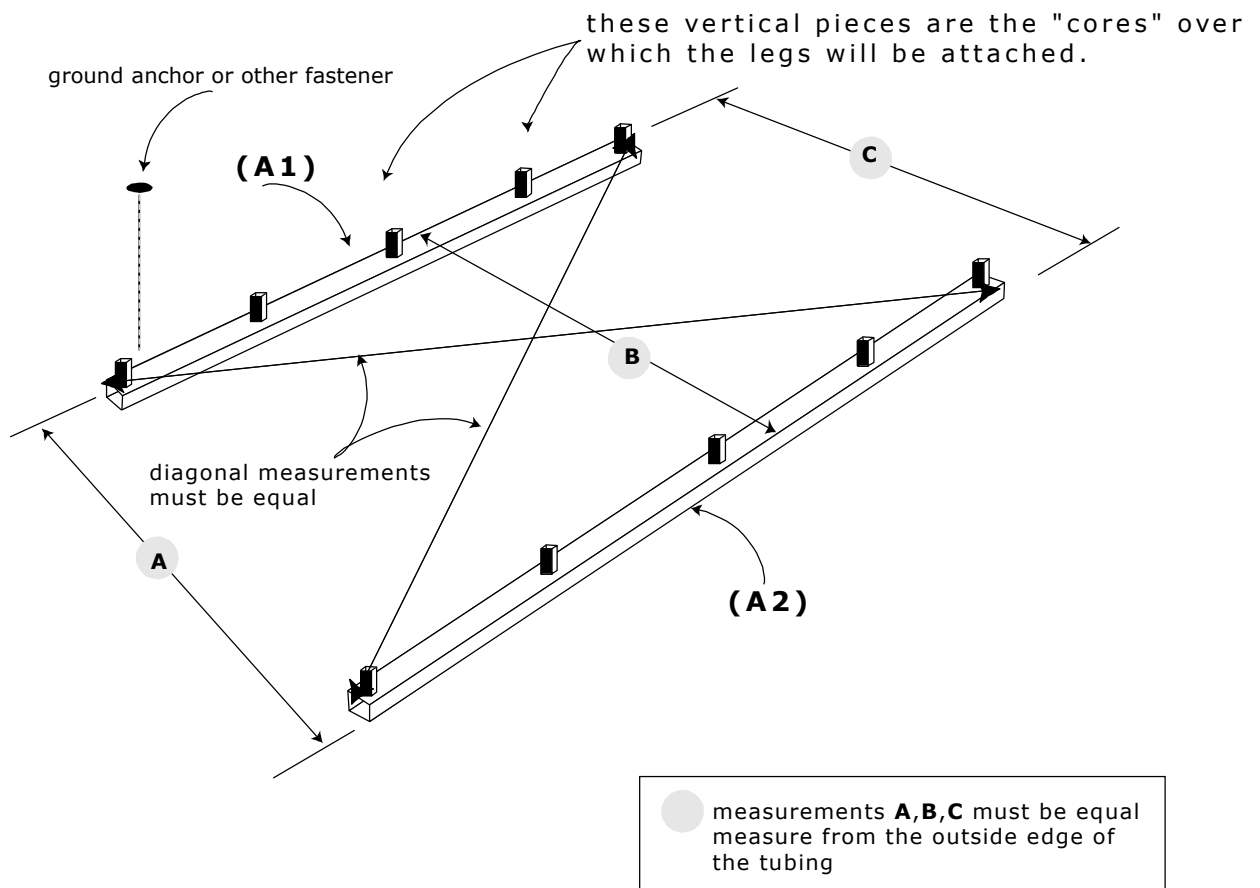

**NOTE: Holes are pre-drilled in baseplates for whatever anchoring system is chosen**

# theCOREsystem™

## ASSEMBLING THE TRUSSES AND LEGS

First, lay the truss on the ground and insert the core pieces into the open ends. Screw off the connection of the truss and the core pieces as shown (only on one side-the side that is facing up). Then slide the side legs over the core pieces and screw off (only on one side-the side that is facing up). Turn the whole assembly over and screw off all the connections.

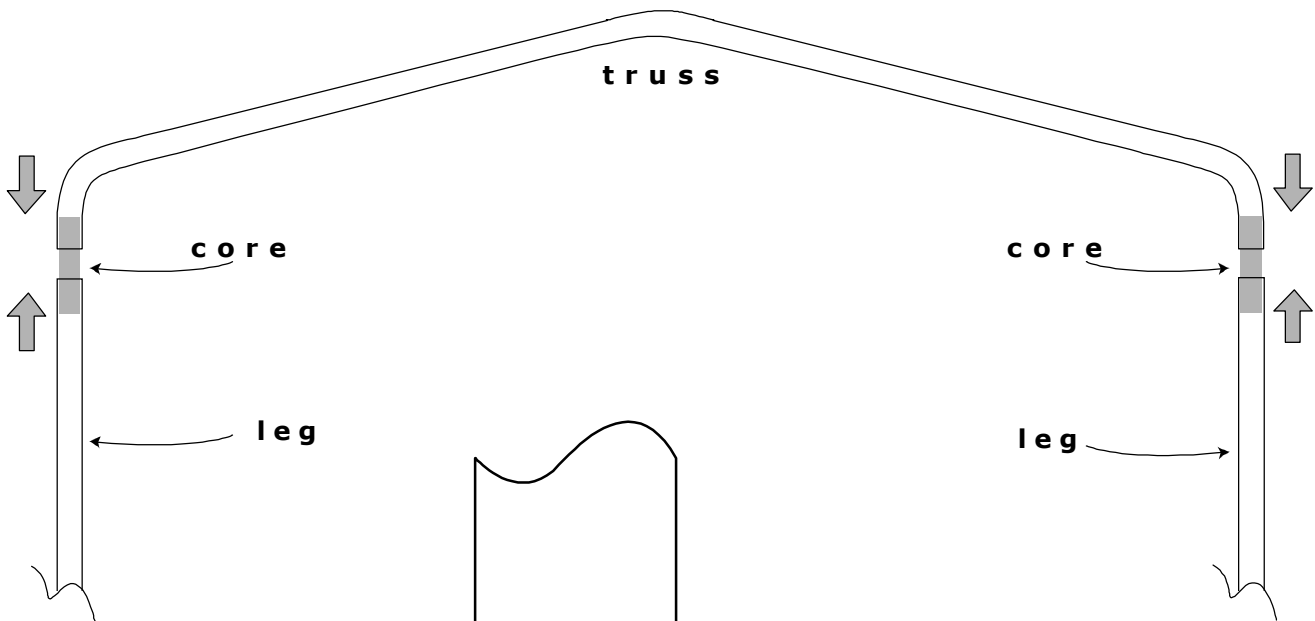

### TRUSS TO LEG screw pattern

The "core" is securely attached to both steel members with a total of 8 stainless steel machine "framing" screws **on each side** of the join.

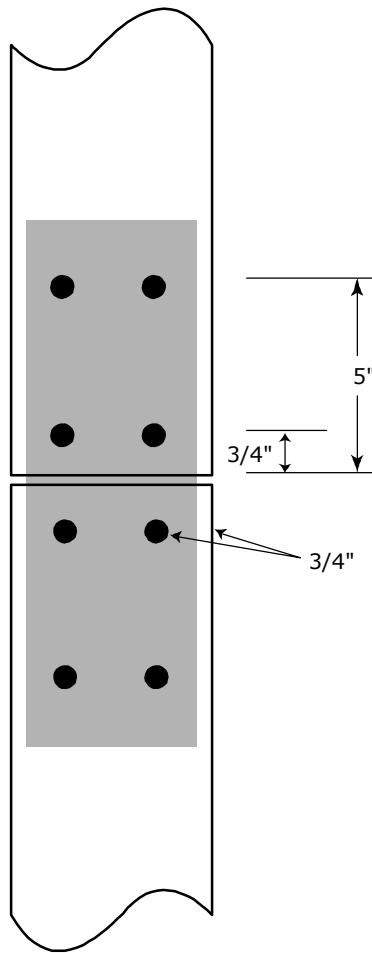

#### HINT:

When joining the legs to the truss section hold a straight-edge (yardstick) along the outside edge to ensure a proper fit.

(ruler/"straight-edge")

This is advisable because there is a small amount of "play" at the join. The more often you check your work in a phases of installation, the better!

# theCOREsystem™

## STANDING THE TRUSS/LEG ASSEMBLY

**WARNING: DO NOT STAND TRUSS/LEG ASSEMBLIES IF THERE ARE ANY WINDY CONDITIONS PRESENT. (SEE SAFETY & HAZARDS INSTRUCTIONS)**

Starting from the "back" (farthest from the front) core pins which is welded to the baseplate, slide the open bottom ends of the truss/leg assembly over the core pins on the baseplate.

The core pins will hold the truss/leg assembly in place temporarily. Stand the remaining truss/leg assemblies.

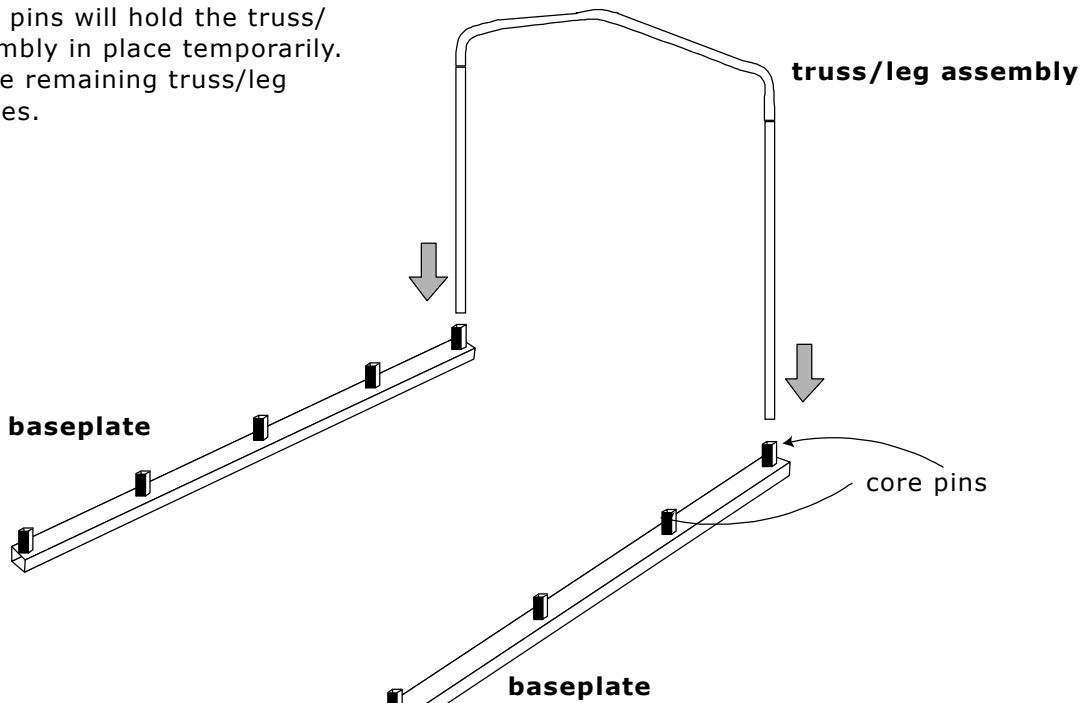

### TRUSS/LEG ASSEMBLY TO BASEPLATE screw pattern

The side leg is securely attached to the base plate/core with a total of 2 stainless steel machine "framing" screws **on each side** of the join.

**NOTE:** The **front** and **back** screw placements "offset" each other.

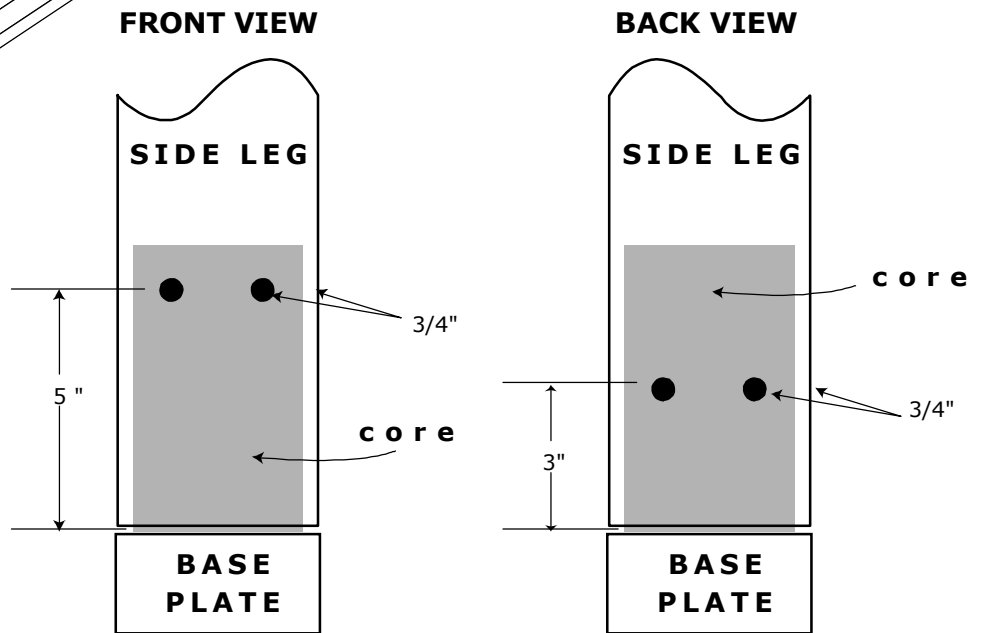

# theCOREsystem™

## HORIZONTAL ROOF SHEETING

**WARNING: DO NOT INSTALL ROOF SHEETING IF THERE ARE ANY WINDY CONDITIONS PRESENT. (SEE SAFETY & HAZARDS INSTRUCTIONS)**

Sheeting can be awkward to handle. It has sharp edges and the wind catches under it easily and it flops around. You want to be organized when starting to attach your sheeting. We suggest laying it out on the ground as it will go on the building. Keeping the sheets squared up is also extremely important as a small mistake on one end of the structure can become a big mistake by the time you get to the other end.

**Study the shape of the sheeting profile. The two edges are not the same. The differences are important.**

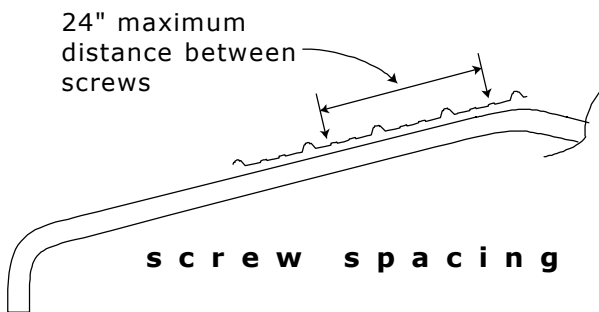
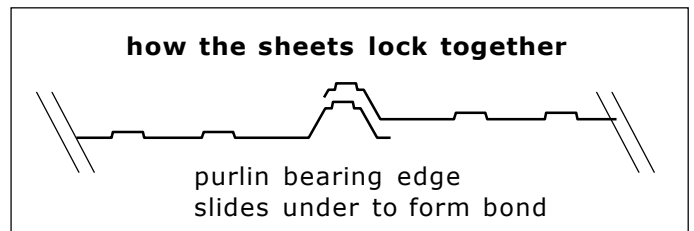
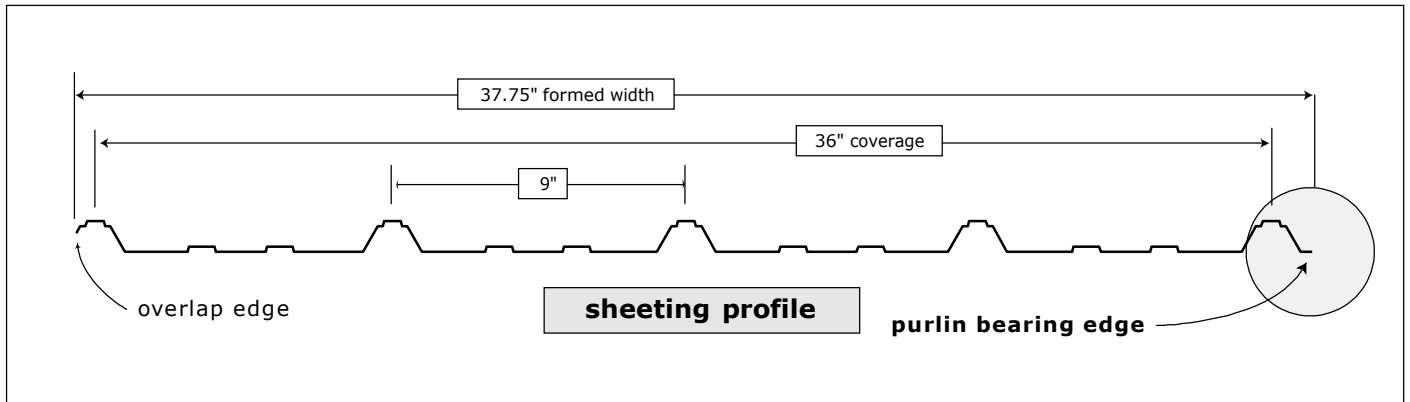

# theCOREsystem™

## HORIZONTAL ROOF SHEETING

Apply the first sheet according to the size of building you have chosen. The number of sheets provided will help determine which option should be used. There are two options. **OPTION ONE**: Mark the center of sheet and apply the first sheet down the center of the roof. **OPTION TWO**: Apply first sheet with edge of sheet running down the center line of roof.

Continue applying sheets, locking together as shown below. Screw into roof trusses. Continue out to end of roof.

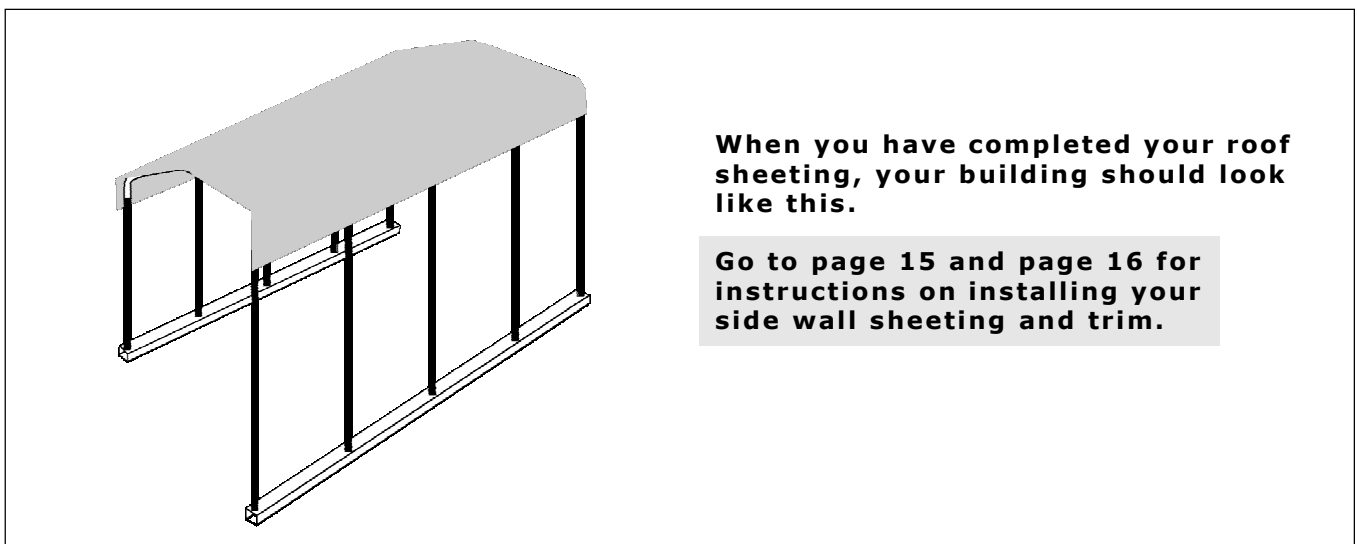
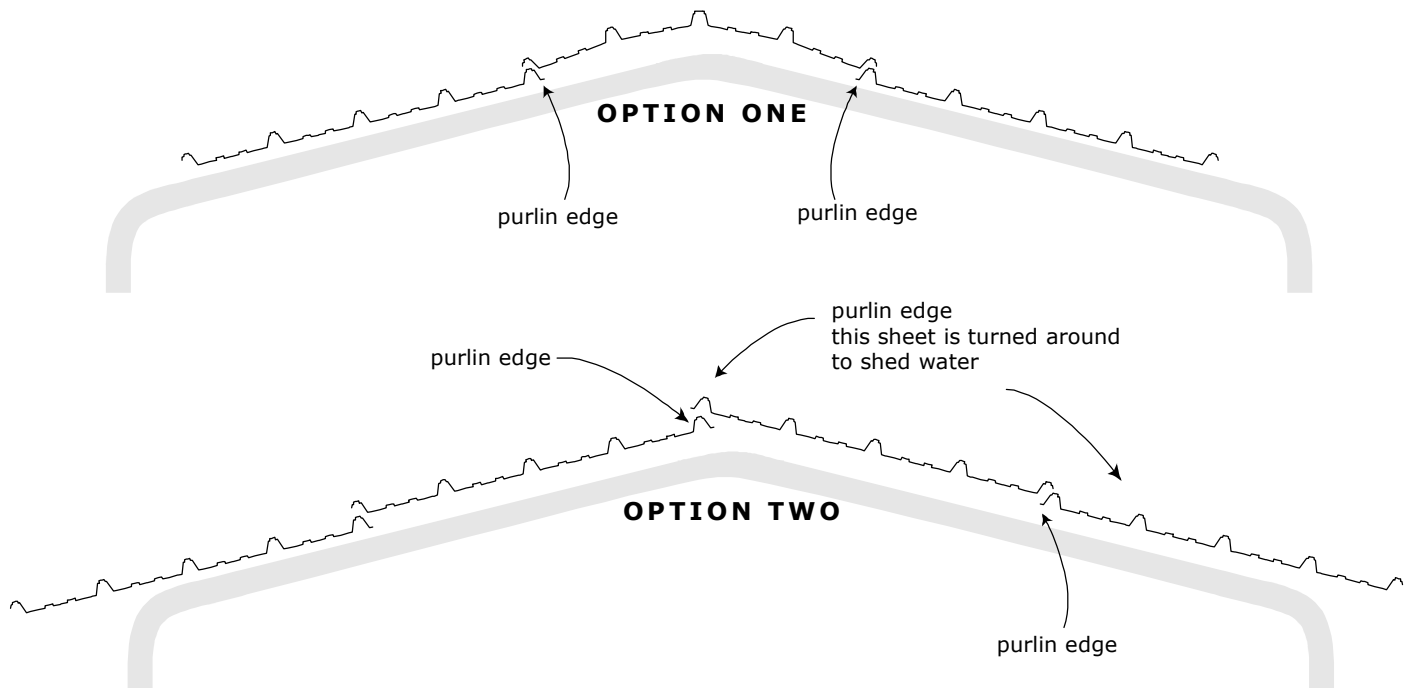

**When you have completed your roof sheeting, your building should look like this.**

**Go to page 15 and page 16 for instructions on installing your side wall sheeting and trim.**

# theCOREsystem™

## VERTICAL ROOF SHEETING

**NOTE:** IF YOU HAVE CHOSEN THE VERTICAL ROOF PACKAGE YOU MUST FIRST INSTALL CORNER BRACKETS ON EVERY TRUSS END (AS SHOWN BELOW) TO SUPPORT THE SHEETING.

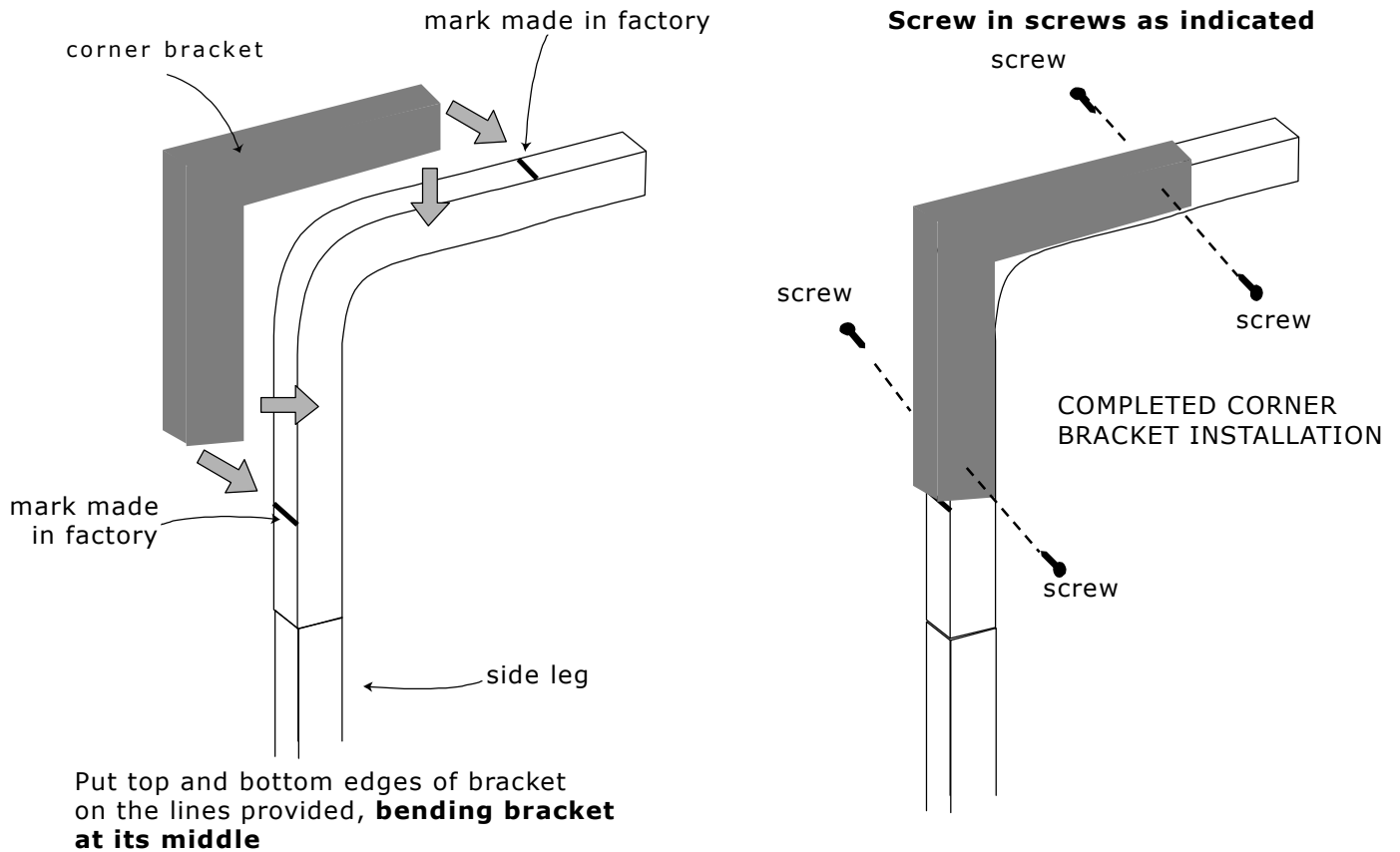
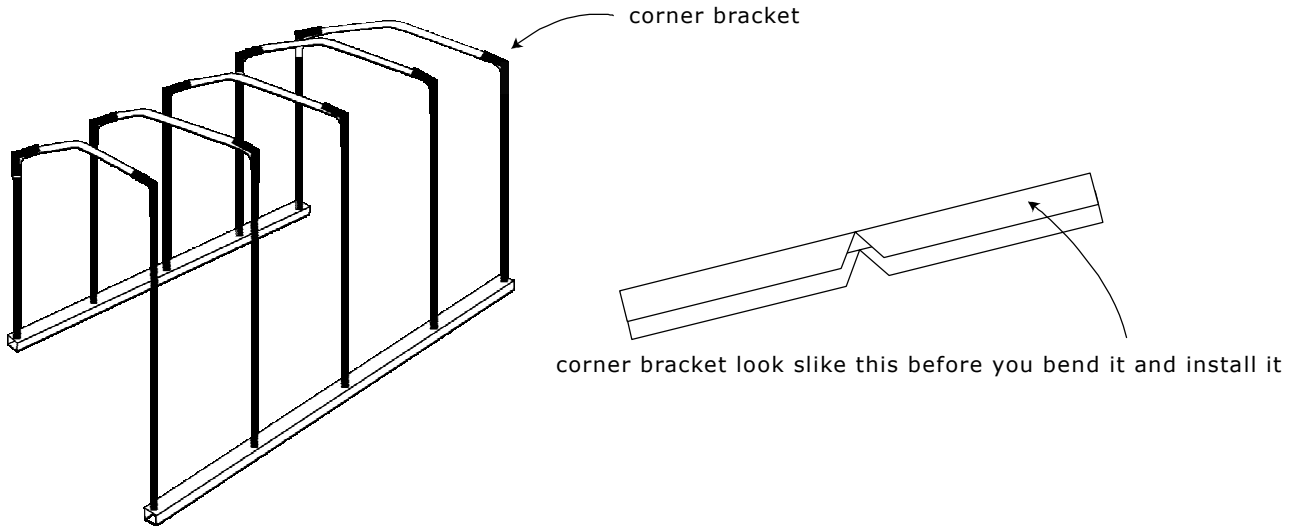

# theCOREsystem™

## VERTICAL ROOF SHEETING

**NOTE:** IF YOU HAVE CHOSEN THE VERTICAL ROOF PACKAGE YOU MUST NEXT INSTALL THE MCGIRT CHANNEL (AFTER INSTALLING THE CORNER BRACKETS) TO SUPPORT THE SHEETING.

Install first stick of McGirt Channel starting from 4" off the center line of the roof truss peak. The center line on each truss is marked in the factory. Also every McGirt channel placement line will be marked in the factory. See drawing below for details on installation. Install outwards on both sides until all sticks are in place.

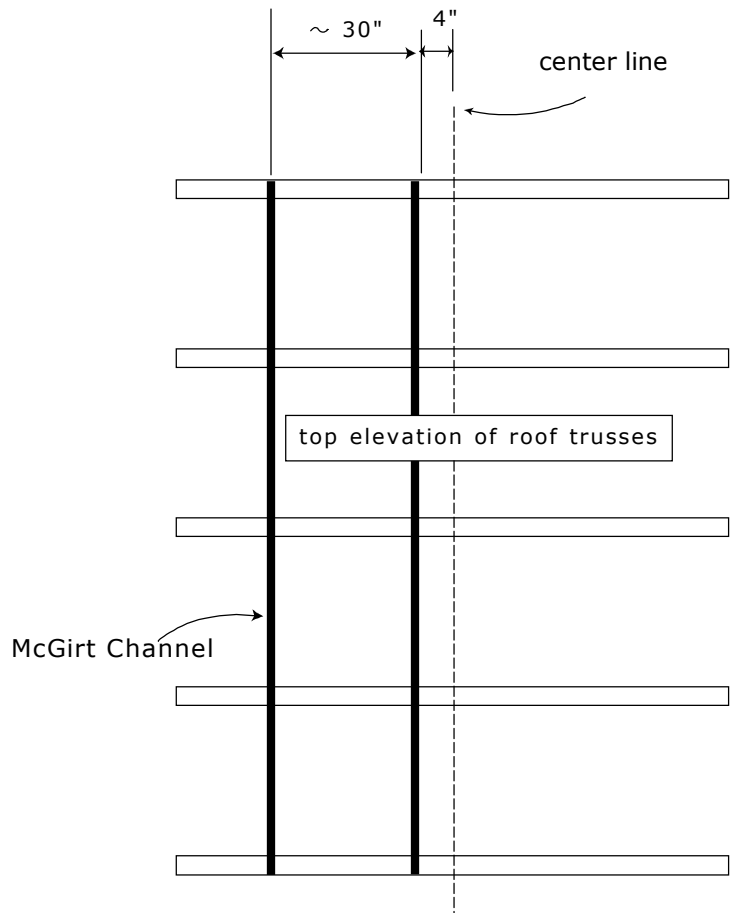
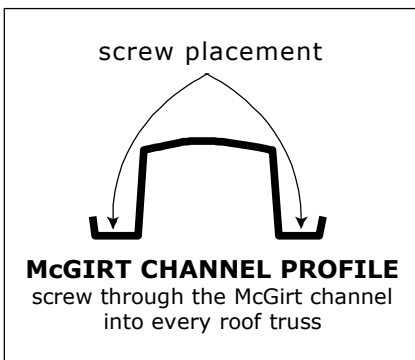
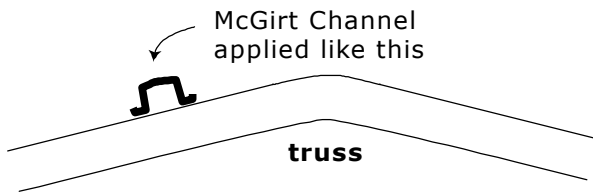
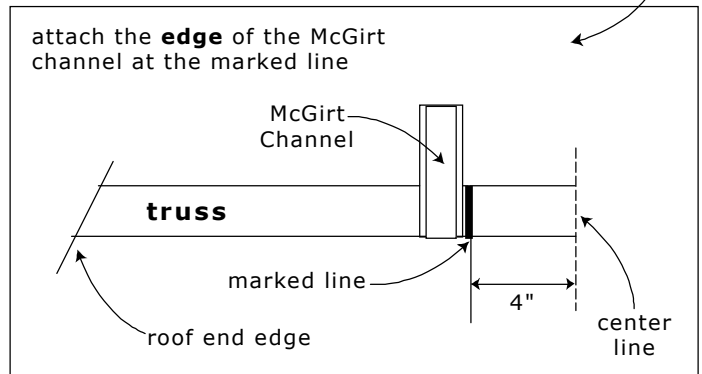
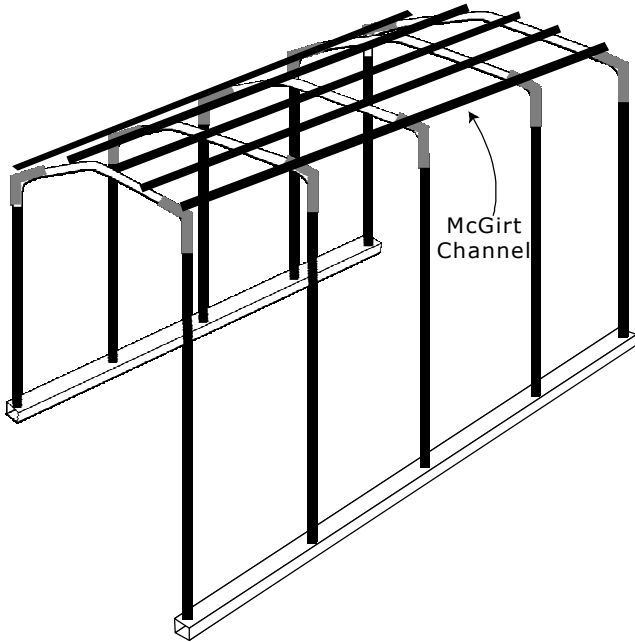

# theCOREsystem™

## VERTICAL ROOF SHEETING

**WARNING: DO NOT INSTALL ROOF SHEETING IF THERE ARE ANY WINDY CONDITIONS PRESENT. (SEE SAFETY & HAZARDS INSTRUCTIONS)**

Sheeting can be awkward to handle. It has sharp edges and the wind catches under it easily and it flops around. You want to be organized when starting to attach your sheeting. We suggest laying it out on the ground as it will go on the building. Keeping the sheets squared up is also extremely important as a small mistake on one end of the structure can become a big mistake by the time you get to the other end.

**Here is a "trick" we like to use.**

Screw in a screw (only half way) on the top of the front roof truss at its center mark and screw in a screw (only half way) on the top of the back roof truss at its center mark then attach an "alignment" string from screw to screw down the length of the building. This will be a helpful guide in the next steps.

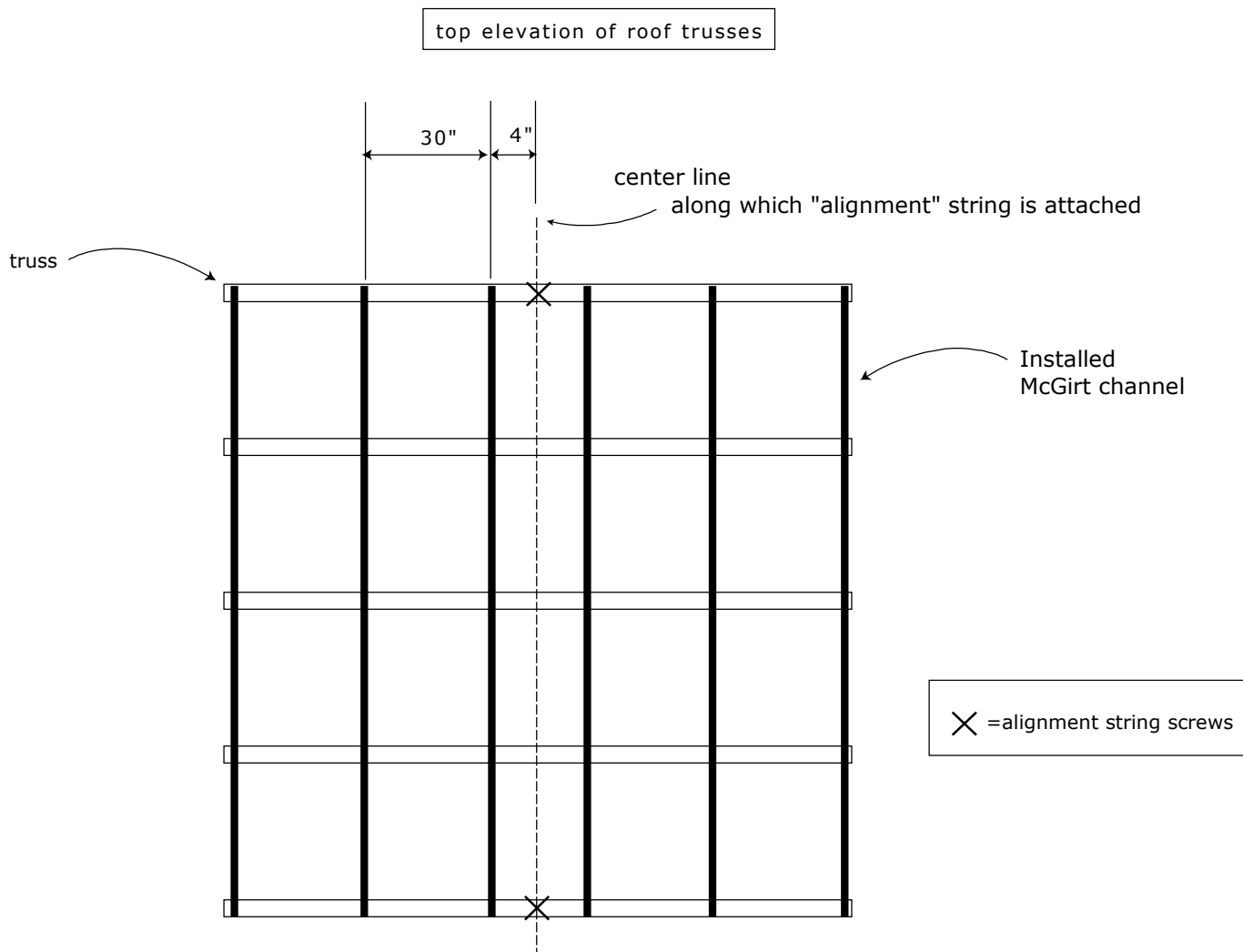

# theCOREsystem™

## VERTICAL ROOF SHEETING

Apply the first sheet at the left front of the building. Line up the top edge of the sheeting with the edge of the McGirt channel closest to the center line (see graphic below) and tack it in with screws. Make sure the leading vertical edge of the sheeting is the purlin bearing edge-this edge goes along the truss line.

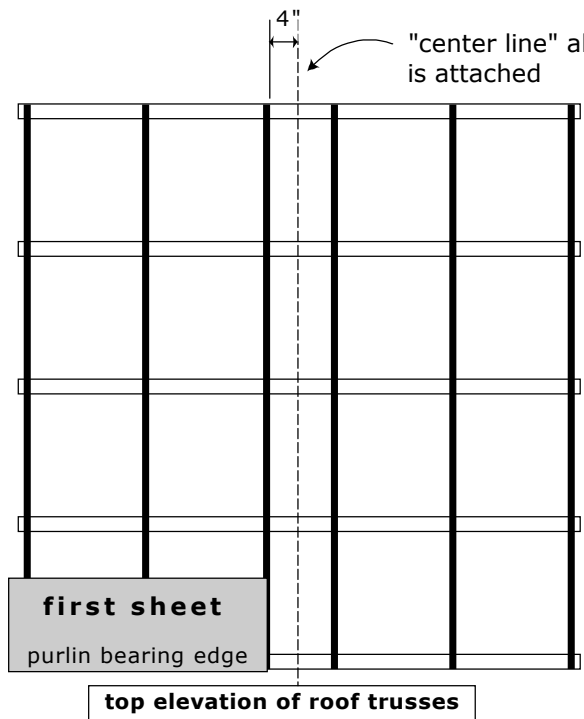
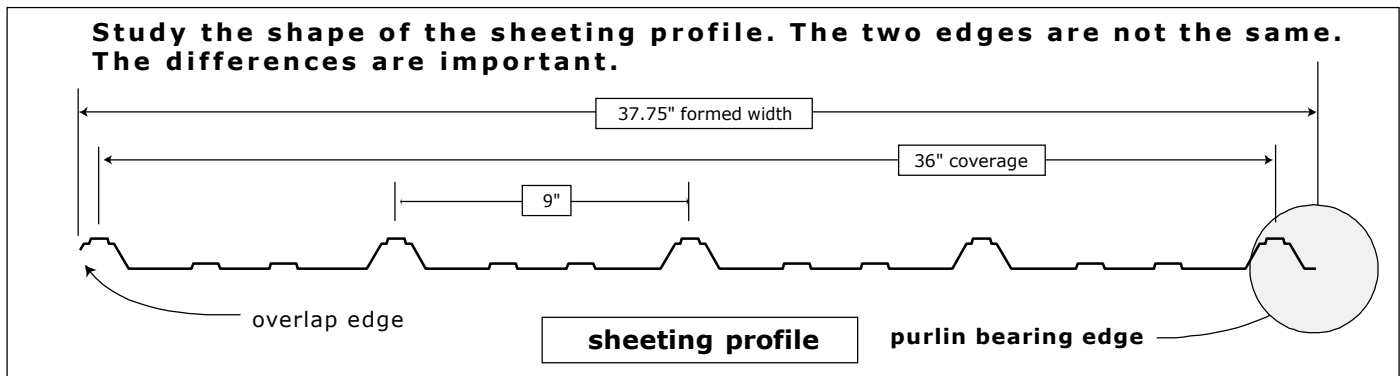

Continue applying sheets all the way to the back of the roof. Check your distance from the center line several times as you progress down the roof to ensure that sheets are squared up.

After 3 sheets you can start to screw off the sheets fully. Make sure that roof is securely screwed down.

Return to the front of roof and go down the right side of roof to the back.

Again checking your square from the center line as you progress.

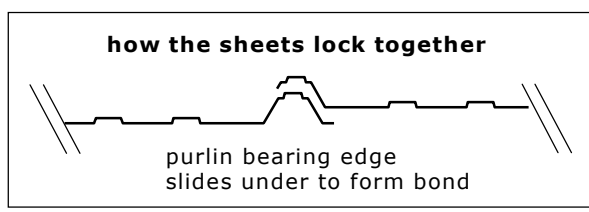
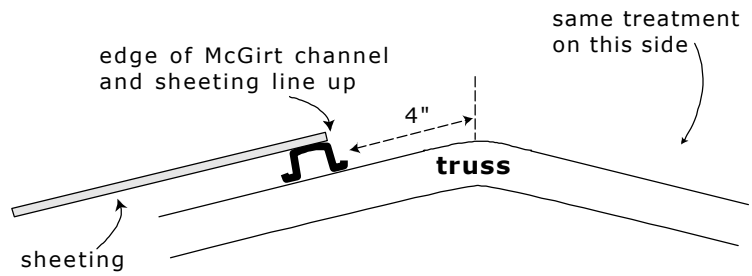

# theCOREsystem™

## VERTICAL ROOF SHEETING-THE RIDGE CAP

Before the ridge cap is installed you must lay down the ridge cap filler. This filler ensures that moisture does not intrude along the ridge cap edge. The filler is a 1-1/4" WIDE x 1" TALL foam barrier strip with a peel-off adhesive along the bottom surface. You peel off the vinyl strip to expose the adhesive and apply to the previously installed roof sheeting as shown below. Then the ridge cap can be installed and the weather-proof seal has been formed.

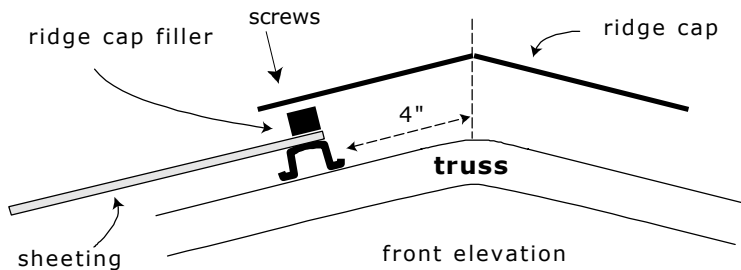
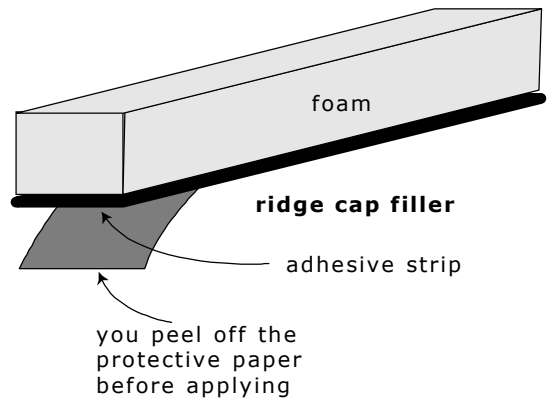
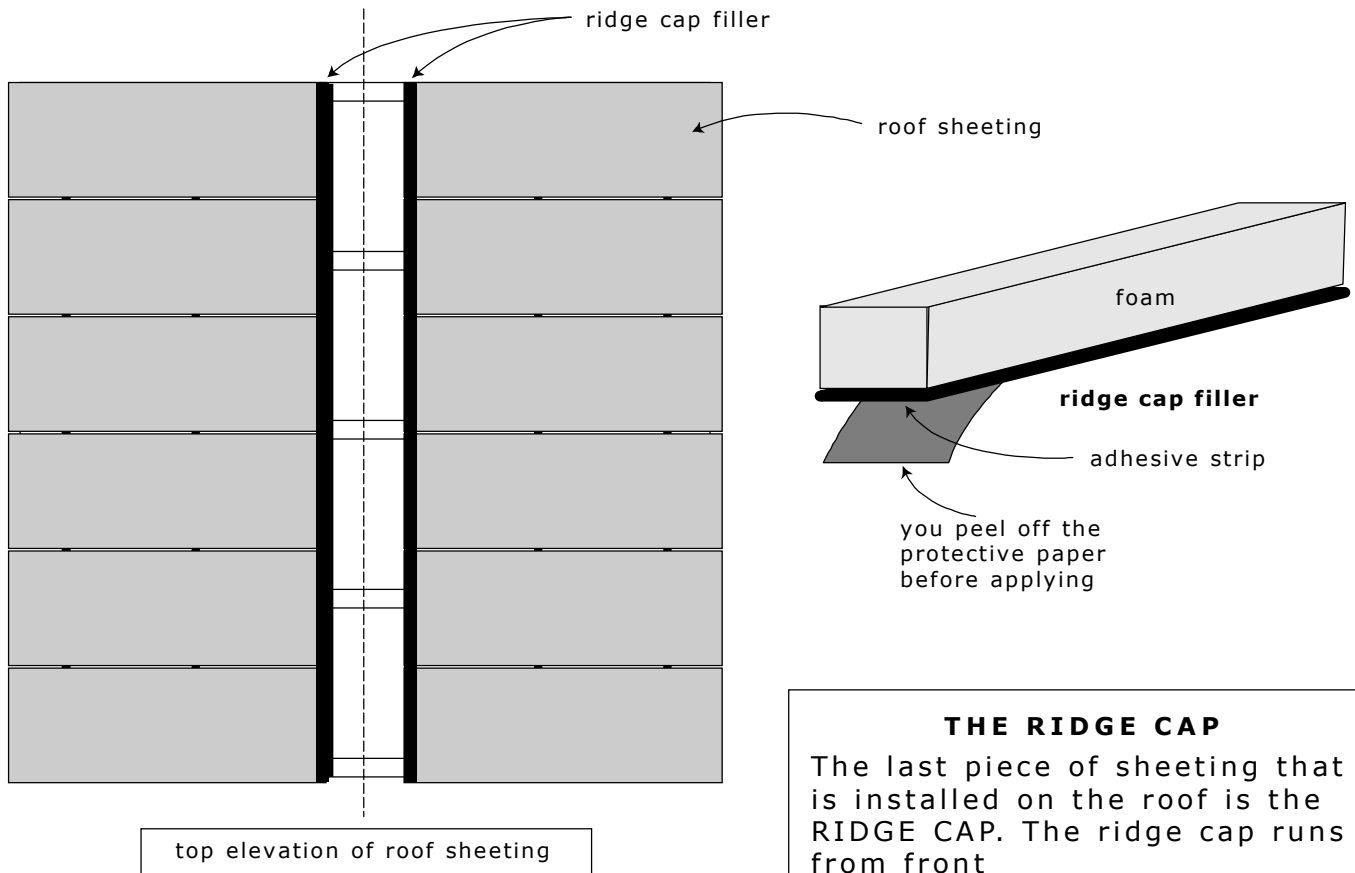

**THE RIDGE CAP**

The last piece of sheeting that is installed on the roof is the RIDGE CAP. The ridge cap runs from front to back and covers the gap in the middle of the roof.

A 3D perspective view of the completed roof structure. The ridge cap is shown running across the top of the roof, covering the gap between the two slopes. A label 'ridge cap' points to the cap.

# theCOREsystem™

## HORIZONTAL WALL SHEETING

**NOTE:**

**WHETHER THE VERTICAL OR HORIZONTAL SHEETING HAS BEEN CHOSEN, THE BUILDING IS FINISHED OFF WITH A SINGLE SHEET OF SHEETING RUNNING HORIZONTALLY DOWN EACH SIDE WHERE THE SIDE LEGS JOIN THE ROOF. THE APPLICATION OF THESE PIECES OF SHEETING IS CRUCIAL TO THE STRUCTURAL STRENGTH AND INTEGRITY OF THE BUILDING AS THEY PROVIDE THE SHEER FACTOR.**

The two sheets will be pre-cut in the factory and all that is necessary is to screw them into each side leg. Three screws per leg will be enough.

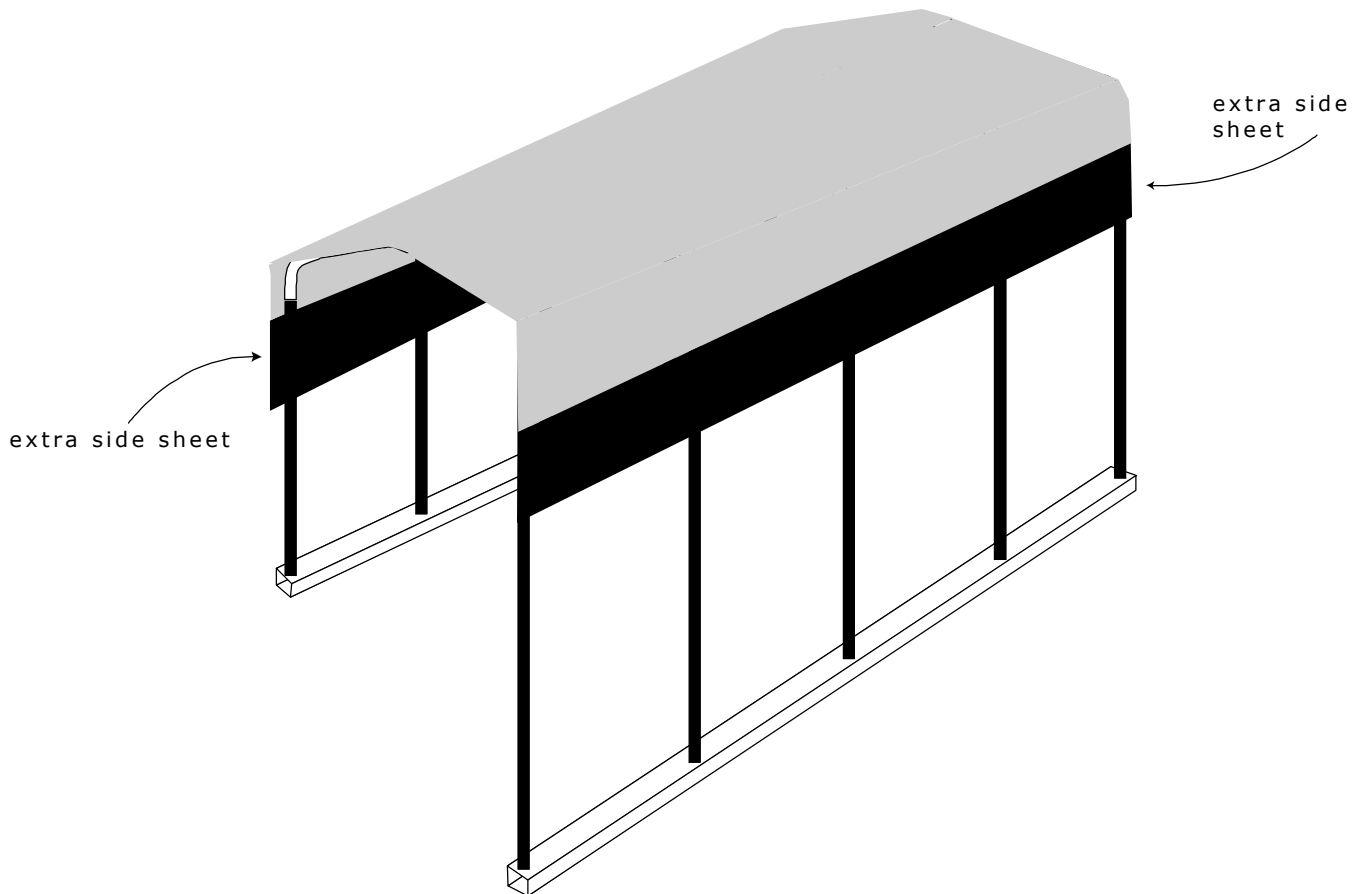

# theCOREsystem™

## INSTALLING TRIM

The trim pieces are installed along the front and back edges of the roof. This leaves a pleasing line along the roof edge. Trim metal comes in 20' lengths. Using tin-snips, cut whatever "fit-cuts" are necessary (such as notches). When the trim pieces fit satisfactorily, they are screwed into the top of front and top of back roof sheeting edges. If you wish to further "trim-out" the building, other trim options are available.

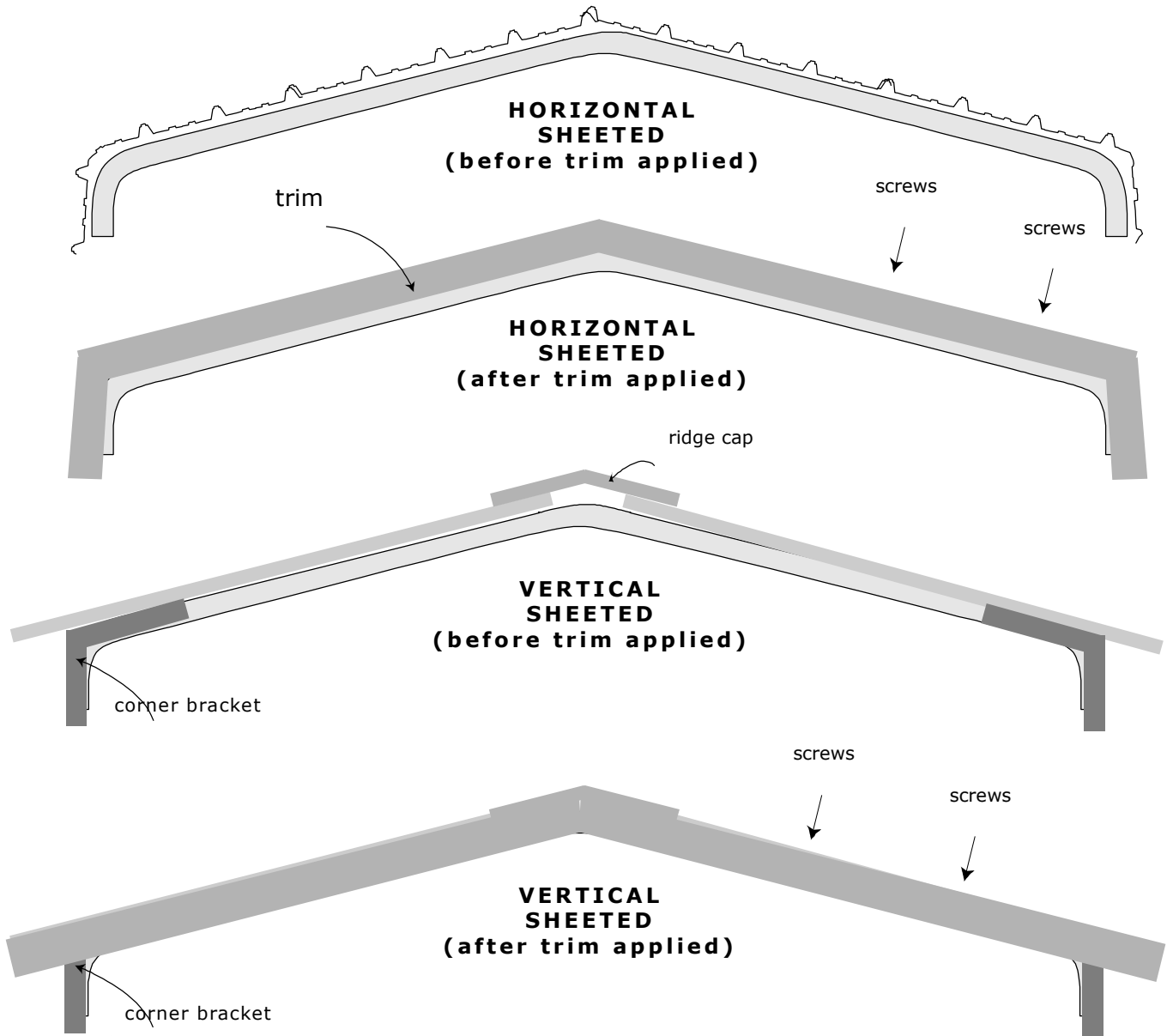

**NOTE:** When you have completed your installation, make sure that you either sweep off or wash off all screw shavings. If left on top of structure they can cause discoloration and/or rust.

# theCOREsystem™

## SCREW SCHEDULES (SHEETING)

### SCREW SCHEDULE FOR 29 ga. HORIZONTAL SHEETING (ROOF, SIDES & BACKS)

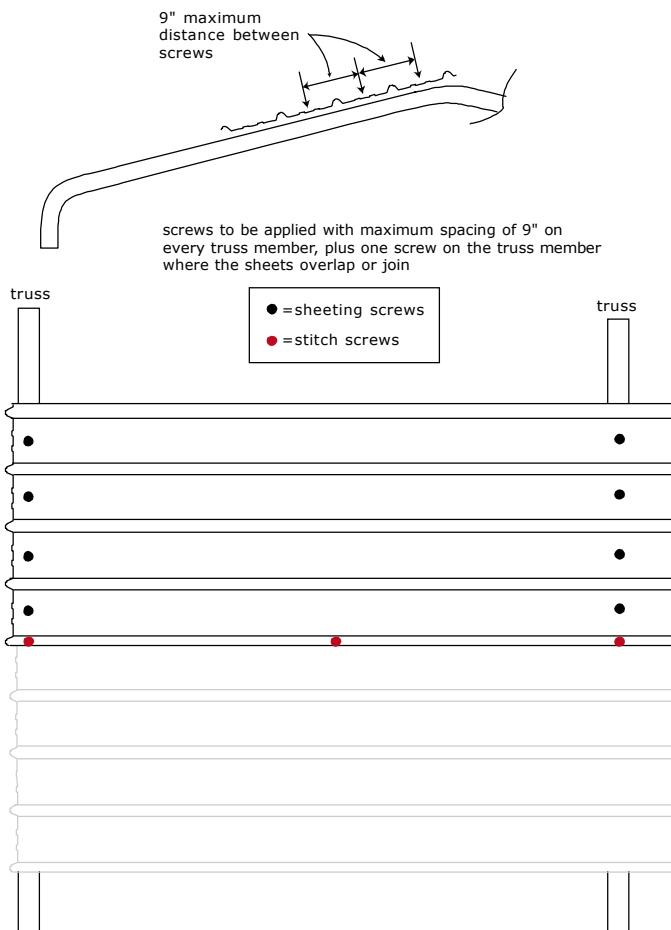

### SCREW SCHEDULE FOR 29ga. VERTICAL SHEETING (ROOF)

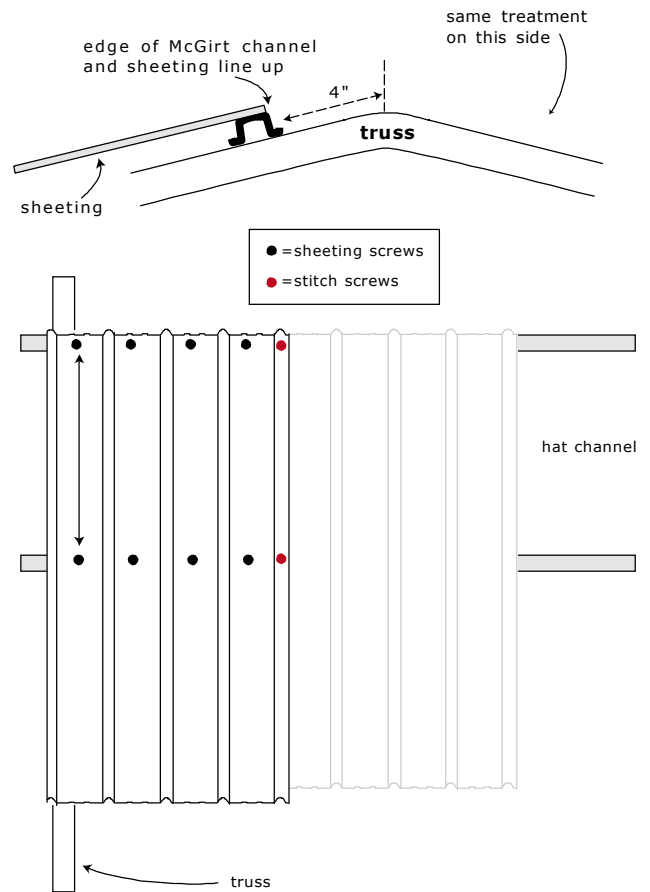

# theCOREsystem™

## SCREW SCHEDULES (FRAMING)

### SCREW SCHEDULE FOR ALL 2" x 3" RECTANGULAR TUBING JOINTS

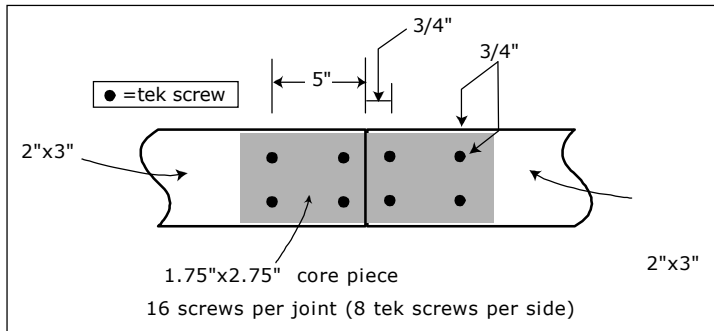

### TRUSS / LEG ASSEMBLY TO BASEPLATE

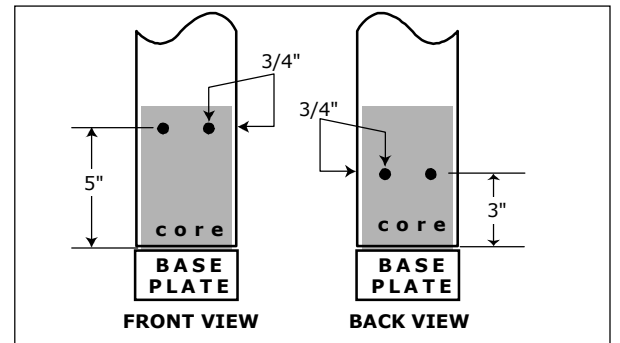

### COLLAR-TIE BRACKET TO TRUSS

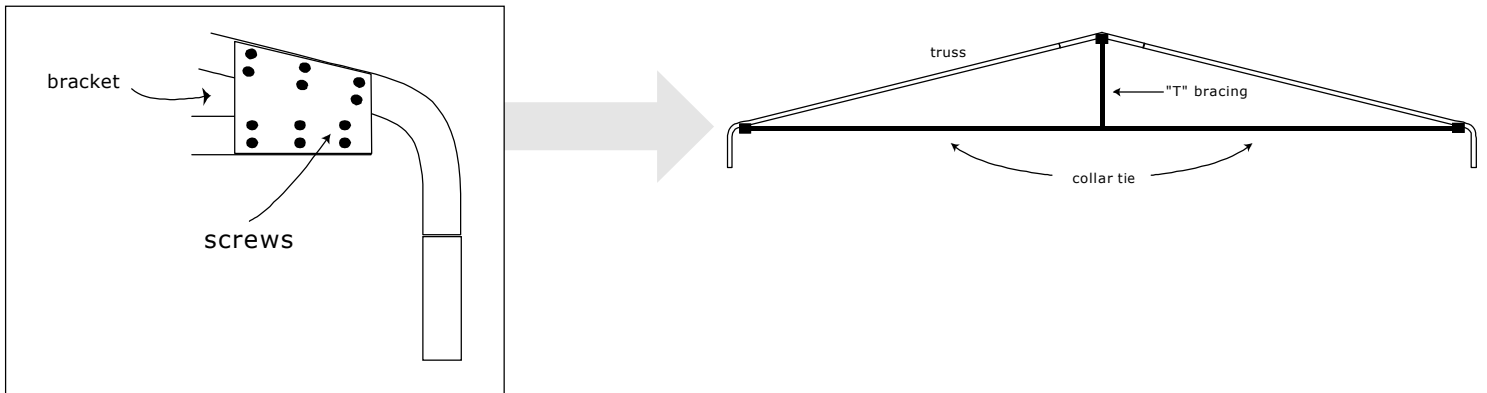

### ATTACHING BACK OR FRONT KIT VERTICALS

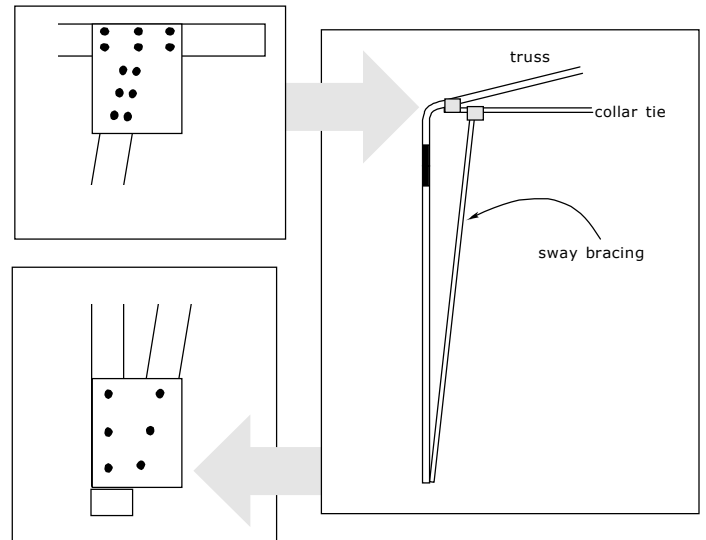
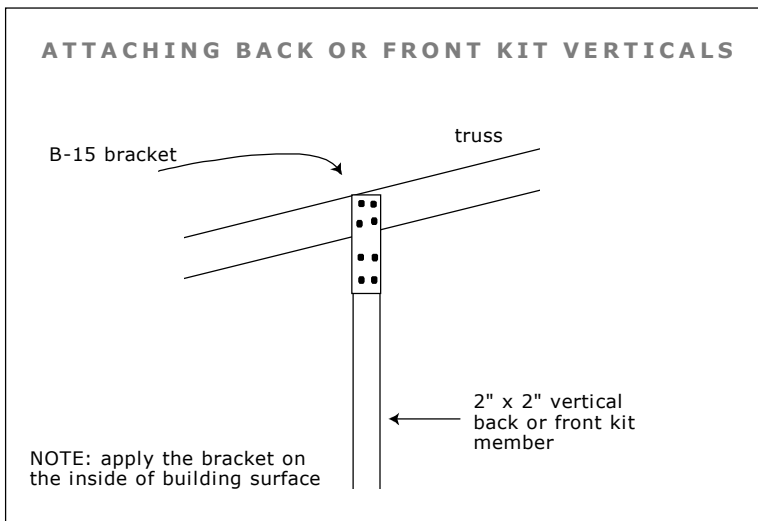

# theCOREsystem™

## FRAMING DOORS & WINDOWS

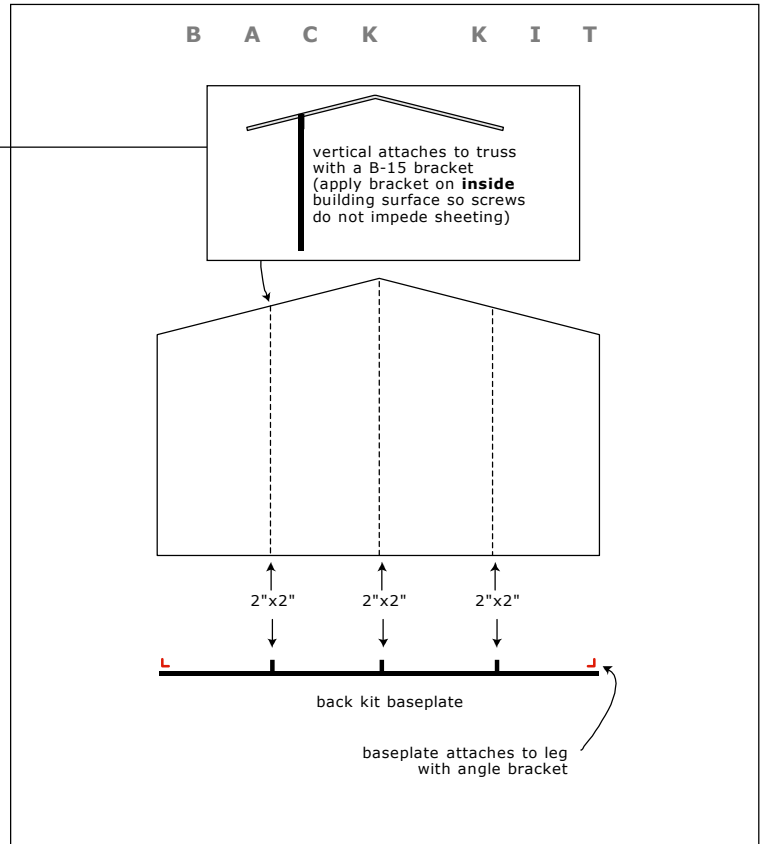
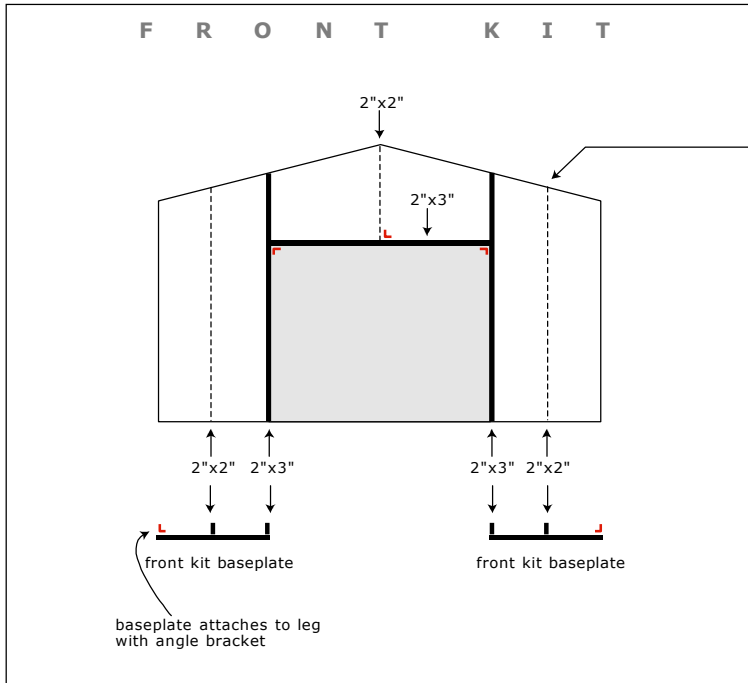

### MAN DOOR FRAMING ON BUILDING SIDE

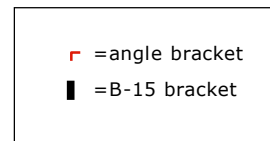
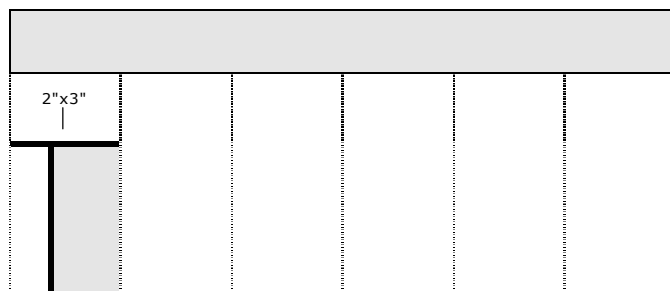

# theCOREsystem™

## COLLAR TIE INSTALLATION

If the width of your building is 20' or above, you will be required to install **COLLAR TIE TRUSS BRACING**. This collar tie gives your building the added structural integrity to pass engineering demands.

### COLLAR TIE INSTALLATION

Bring collar tie piece up tightly under the truss bow secure with B-57 plate-brackets (as shown in "screw pattern")

